

BLANKING SUPPORT UNIT

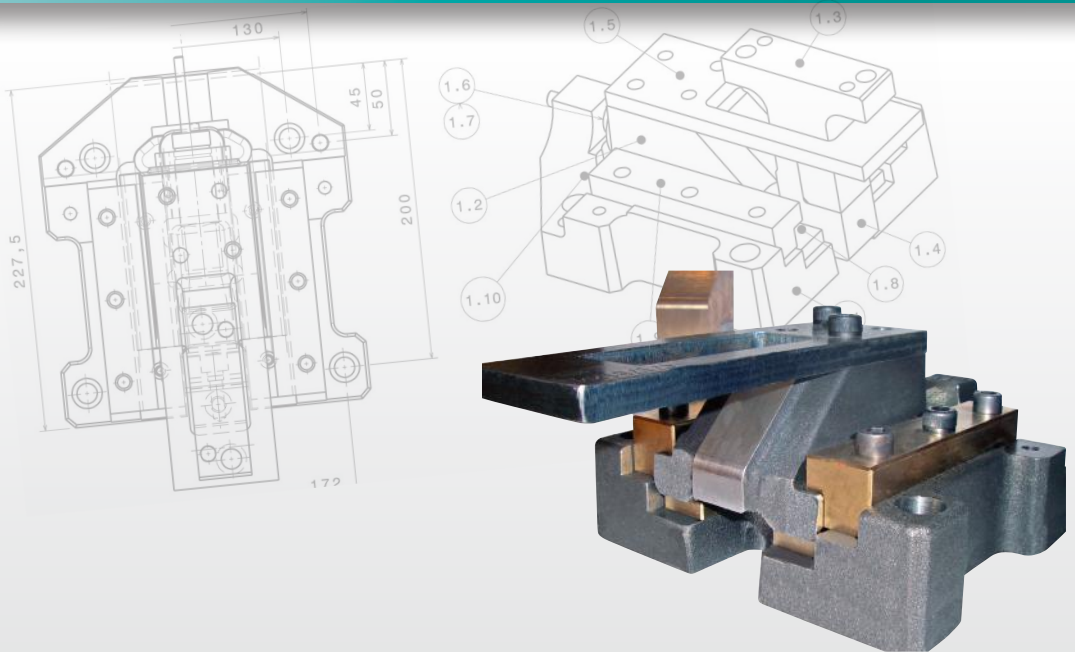

For stabilization
of the metal sheet

Blanking Support Unit - to stabilize the coil during transport in blanking dies over long and deep side cuts

Features:

- Stroke up to 45 mm maximum
- Adjustment of time and duration of the working stroke
- Maintenance free slide elements according VDI
- ISO gas spring
- Slider is positive locked inside base
- Rear damper as option

Bill of material:

Blase:	1 pc	SUB45	1.1
Slider:	1 pc	SUB45	1.2
Driver:	1 pc	SUB45	1.3
Dwell plate:	1 pc	SUB45	1.4
Connection:	1 pc	SUB45	1.5
Gas spring:	1 pc	SUB45	1.6
Mounting flange:	1 pc	SUB45	1.7
Slide plate:	2 pc	SUB45	1.8
Angle plate:	2 pc	SUB45	1.9
Damper (Option):	1 pc	SUB45	1.10

